

CoolPointTM

Installation and Operation Manual

Vortex Shedding Flowmeters For Flow Rate

Series:

CP6, CP8, CP12, CP16, CP24 and CP32

Effective with products having serial number 070200000 and greater

UNIVERSAL FLOW MONITORS, INC.

1755 East Nine Mile Road

PO Box 249

Hazel Park, MI 48030-0249

TEL (248) 542-9635 FAX (248) 398-4274

Website: <http://www.flowmeters.com>

TABLE OF CONTENTS

TABLE OF CONTENTS..... 2
PROPRIETARY NOTICE 3
USING THIS MANUAL 3
NAMEPLATE EXAMPLE – CP6 through 32 (Flow) 3
GENERAL SPECIFICATIONS 4
WIRING DIAGRAMS (Pin Configurations) 6
OPERATION..... 9
APPLICATIONS 9
INSTALLATION 10
SETUP AND CONFIGURATION FOR STANDARD FLOW AND/OR TEMPERATURE UNITS
(NOT D2 TOTALIZING UNITS) 10
 Factory Default Settings 10
 Initial Power Up – Models CP6-CP32 11
 Configuring the solid state relay as pulse output: 13
 Configuring response time in filter mode:..... 14
 Step Response Graphs for Various Filter Settings 15
 Configuring the CP models with the E2:..... 16
MODEL CODES 17
PRESSURE DROP CHARTS 19
CABLING..... 19
DIMENSIONS..... 20
RMA NOTICE RETURN MERCHANDISE AUTHORIZATION 21
RMA FORM..... 22
WARRANTY INFORMATION 23

PROPRIETARY NOTICE

The information contained in this publication is derived in part from proprietary and patented data. This information has been prepared for the express purpose of assisting in installation, operation, and maintenance of the instruments described herein. Publication of this information does not convey any rights of use or reproduction other than in connection with the installation, operation and maintenance of the equipment described herein. Universal Flow Monitors, Inc. reserves the right to change the information contained in this publication at any time and without prior notice.

USING THIS MANUAL

In order to use this manual, you will need the model code that can be found on the nameplate of the flowmeter, as shown on the example below (see [MODEL CODES](#)). The Model Code allows you to determine minimum and maximum flow capabilities, as well as pressure drop for various sizes.

NAMEPLATE EXAMPLE – CP6 through 32 (Flow)

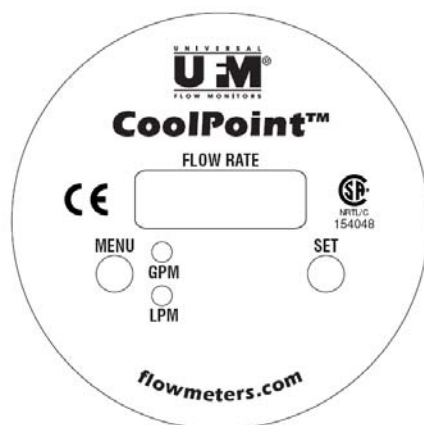
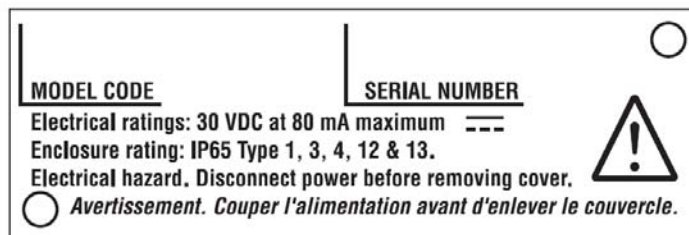

GENERAL SPECIFICATIONS

Maximum Operating Pressure:	200 PSIG (13.6 Bar) for CP24, CT24, CP32, CT32 300 PSIG (20.4 Bar) for CP6, CP12, CP16, CT6, CT12 and CT16
Minimum Operating Pressure:	10 PSI of back pressure is required for the formation of vortices. See INSTALLATION and PRESSURE DROP CHARTS
Maximum Operating Temperature:	185 °F (85 °C), 186-210 °F (85-99 °C) with reduced rating of the solid-state relay (fluid and ambient temperature) Optionally the CP units (flow only) can have the maximum temperature extended to 225 °F for 1 hour maximum duration. At the elevated temperature, the solid state relay does not function until resumption of normal temperatures.
Minimum Operating Temperature:	35 °F (2 °C) fluid and ambient
Maximum Flow:	Meters may occasionally be over-ranged up to 125% of capacity without damaging the meter. Note: Output is clamped at 21mA (6.3% over-range) but the display will indicate up to 125% F.S.
Capacities:	3/4" = 25 GPM (95 LPM) 1" = 50 GPM (190 LPM) 1 1/2" = 100 GPM (380 LPM) 2" = 200 GPM (750 LPM) 3" = 300 GPM (1136 LPM) 4" = 600 GPM (2271 LPM)
Turndown Ratio:	10:1 standard. 20:1 optional for CP6, CP8, CP12, CP16, CT6, CT8, CT12 and CT16
Process Connections:	Female NPT for 2 inch pipe sizes and below. This would include CP 2-16 and CT 6-16. ANSI RF (Raised Face) flange for 3" and 4" sizes including CP24-32 and CT24-32
Wetted Parts:	Brass, PVDF and Viton®. 316 Stainless Steel optional for all sizes up to 2" (CP6, 12, 16 as well as CT 6, 12, 16)
Display:	3-digit LED for CP6-CP16, CT2-CT16 4-digit LED for CP24, CP32, CT24, CT32 Digit height = 0.3"
Enclosure Rating:	Type 1, 3, 4, 12, 13, IP65
Power:	10 - 30 VDC @ 80 mA



Caution: The unit shall be supplied by a SELV (separated extra-low voltage) source in accordance with CSA Standard C22.2 No.1010.1-92 Annex H.

Environmental conditions:	This device has been designed for use in Installation Category I, pollution degree 4, at altitudes up to 2000 meters (6560 ft.), either indoors or outdoors as defined in CSA Standard C22.2 No.1010.1-92.
---------------------------	--

*Viton® is a registered trademark for DuPont Performance Elastomers.

Features Common to all 4-20 mA Units

Electrical Service:	General Purpose
Electrical Classification:	Non-hazardous Type 1, 2, 3, 4 (equal to IP 65), 12, and 13
Power Requirements:	24 VDC (10-30 VDC) @ 80 mA
Cabling:	Male DC micro pin connector standard, pigtails or conduit box optional.
Accuracy:	± 2% of full-scale
Analog Output:	4-20 mA proportional to flow
Response Time:	0.9-7.5 seconds to 63% of step change (user selectable)
Repeatability:	± 0.25% of actual flow
Alarm Output:	Optically-isolated solid-state relay, rated to 125 mA @ 30 VDC, up to 185 °F [50 mA @ 30 VDC between 186-210 °F (85-99 °C)] Alarm Deadband = 5% of full-scale Alarm State = NO or NC above setpoint (selectable)
Pulse Output:	100 pulses per gallon (for ¾" to 1 ½" port size) 25 pulses per gallon (for 2" port size and up) 3 msec minimum pulsewidth 30 VDC maximum pulse amplitude (based on the relay rating) Note: Standard units have a solid state relay in addition to the transmitted output and it is field selectable to either be a pulse output or a flow alarm. When pulse output is selected, the relay contact is closed for a minimum of 3 milliseconds. Relay on-resistance is 10 ohms.
Grounding:	Note that DC and Chassis Grounds are internally connected to eliminate electrical noise. If this poses a problem with your control wiring, please contact UFM for alternative wiring. Do not connect shielding at the panel.

WIRING DIAGRAMS (Pin Configurations)

CP (Flow) All Models, Unless Otherwise Noted

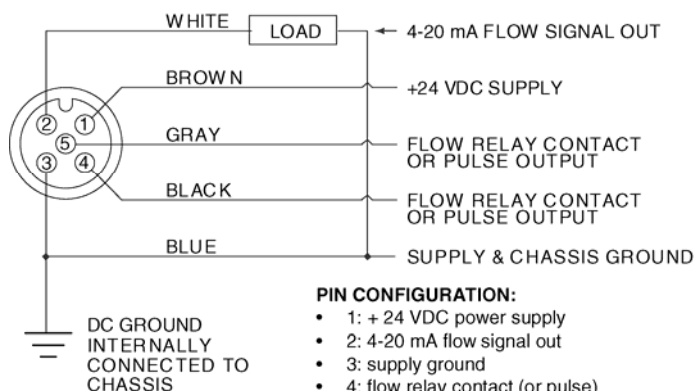

Note: For pulse output, the flow relay contact is closed for 3 msec (pulsewidth)

E2 Output: CP2-CP4

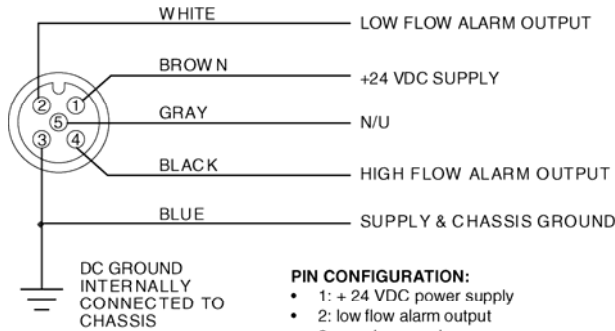

- PIN CONFIGURATION:**
- 1: + 24 VDC power supply
 - 2: low flow alarm output
 - 3: supply ground
 - 4: high flow alarm output
 - 5: not used

Note: There are internal 10K pull-up resistors from pins 2 and 4 to supply voltage.

E2 Output: CP6-CP32

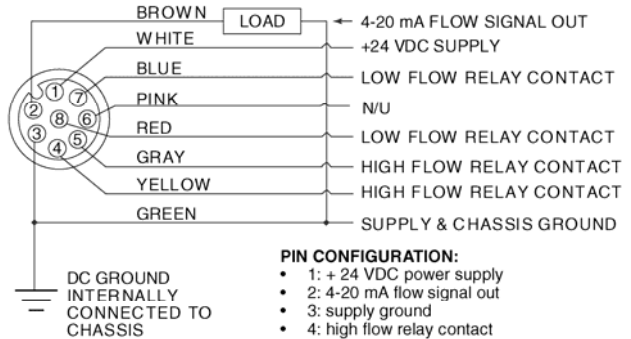

- PIN CONFIGURATION:**
- 1: + 24 VDC power supply
 - 2: 4-20 mA flow signal out
 - 3: supply ground
 - 4: high flow relay contact
 - 5: high flow relay contact
 - 6: not used
 - 7: low flow relay contact
 - 8: low flow relay contact

Note: Alarm relays are solid-state (SSR), and have no positive or negative polarity. Maximum internal "on" resistance is 15 ohms.

E3 Output: CP2-CP32

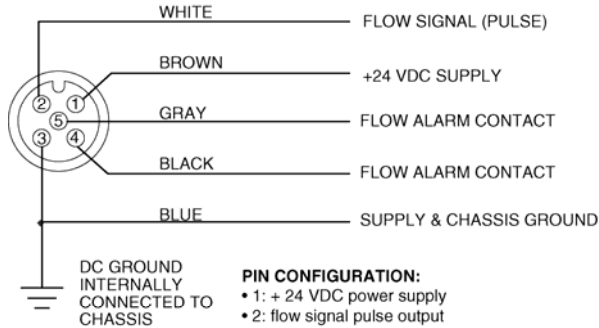

- PIN CONFIGURATION:**
- 1: + 24 VDC power supply
 - 2: flow signal pulse output
 - 3: supply ground
 - 4: flow alarm contact
 - 5: flow alarm contact

Note 1: Alarm relay is solid-state (SSR), and has no positive or negative polarity. Maximum internal "on" resistance is 15 ohms.
 Note 2: There is an internal 10K pull-up on the pulse output line (pin 2).

E8 Output: CP2-CP32

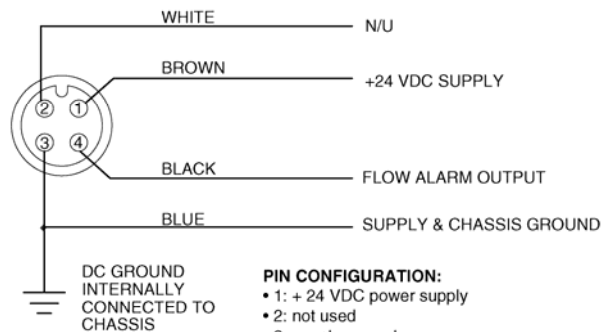

- PIN CONFIGURATION:**
- 1: + 24 VDC power supply
 - 2: not used
 - 3: supply ground
 - 4: flow alarm output (24V = fault)

Note 1: Alarm output is driven by an internal solid-state relay (SSR), with a maximum internal "on" resistance of 15 ohms.
 Note 2: There is an internal 5K pull-up on the alarm output line (pin 4) to provide 24V in flow fault. This line "floats" (i.e., open-circuit) when the alarm condition is cleared.

DC Power Supply Voltage Requirements for 4-20 mA Outputs:

- **CP (flow output)**

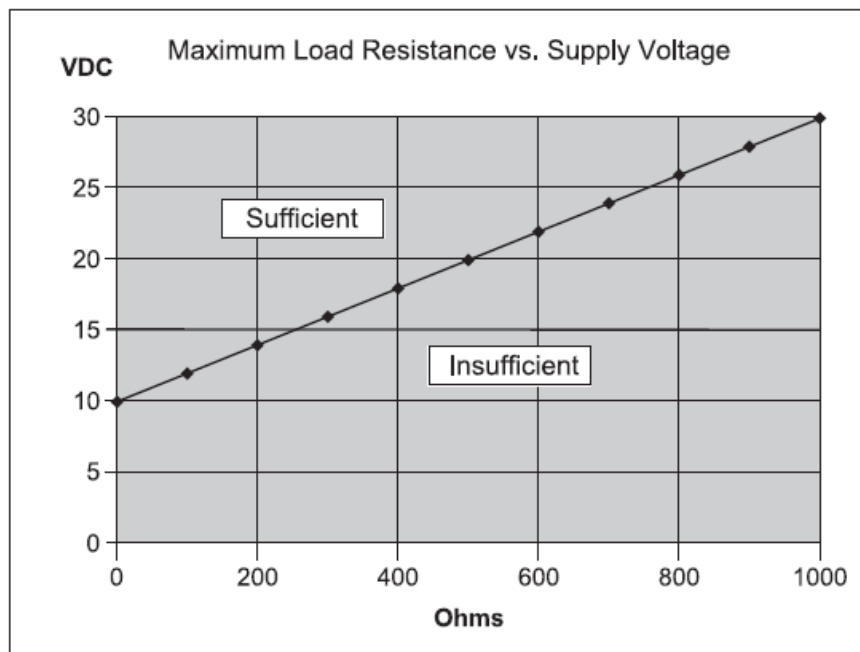

OPERATION

CoolPoint is an inline flowmeter that utilizes the vortex shedding principle. The fluid strikes a bluff body, generating vortices (eddies) that move downstream. The vortices form alternately, from one side to the other. A piezoelectric sensor housed in a sensor tube directly downstream of the bluff senses the pressure zones created by the vortices. The sensor generates a frequency directly proportional to the vortices (flow). The pulses are then amplified by the circuit board and converted to a 4-20 mA output, which is also linear with flow. Flow is displayed on the LEDs in either GPM or LPM. Selection of the preferred units of measure is made by using the **SET** pushbutton. A solid-state relay can also be set for a low-flow alarm, typically from 15% to 90% of full-scale flow. The relay can be configured to be either NC (normally-closed) or NO (normally-open), or for a pulse output.

APPLICATIONS

CoolPoint can be used on low viscosity, clean or dirty water-like liquids that are compatible with brass, PVDF and Viton. Metered fluids should not include long fibers or a significant level of abrasive solids. Should abrasive wear occur over time, bluffs as well as the sensors are replaceable. Typical applications include cooling loops using water, 50% solutions of glycol, and water-soluble machine coolant (up to 10%). These applications are found in most process industries, including rubber, steel, fabrication, manufacturing, refining, paper, chemical, food, petrochemical and power. They cannot be used on gases (including air), or on flammable liquids.

Note: If used outside the parameters specified in this manual, the proper operation of the flowmeter cannot be guaranteed.

Cleaning: These meters do not require any special cleaning of the external surfaces. If cleaning is deemed necessary, strong solvents, detergents, or chemicals should not be used. A damp cloth may be used to wipe off dirt or debris.

INSTALLATION

For best results, the meters may be installed in any position as long as proper piping installation requirements are observed. This includes sufficient support of adjacent piping to minimize the system's inherent vibration. Unions of the same pipe size and full port isolation ball valves may be installed for ease of removal and servicing of equipment, if necessary. Meters should be placed in horizontal, slightly ascending runs or vertical runs to prevent trapped air from accumulating in the meter. Furthermore, the meters should not be placed at the highest point in the piping. The piping system should be filled slowly to prevent water hammer from damaging the flow sensor. Please note that reverse flow can also damage the flow sensor.

In order to achieve the stated accuracy, a straight pipe run of 10 pipe-diameters (minimum) is required upstream of the meter, as well as 5 pipe-diameters downstream. Isolation ball valves, when used, should be in the full open position. Throttling valves should always be placed downstream of the meter. A minimum straight run of 50 pipe-diameters is required between an upstream valve and the flowmeter.

If Teflon® tape or pipe sealant is used, the user must ensure that no loose parts become wrapped around the bluff or the flow sensor when flow starts.

Use of diaphragm or piston pumps affects the meter's performance unless they are installed with a properly sized pulsation dampener and pressure control. The piping system must create some backpressure on the meter to allow vortex formation and to prevent cavitation, especially at full flow. Minimum required backpressure is 10 PSIG at maximum flow and at 70 °F (21 °C). Higher backpressures are required at elevated temperatures and occasional surges to 125% of maximum flow.

In rare situations, the user may notice an intermittent flow display that drops off while the flow is held steady. In this case, please contact UFM to discuss the backpressure requirements.

SETUP AND CONFIGURATION FOR STANDARD FLOW AND/OR TEMPERATURE UNITS (NOT D2 TOTALIZING UNITS)

Factory Default Settings

Flow Units: GPM

Set Point: 00.0. NO/NC is set to NC. Flow averaging filter set to F 08

Initial Power Up – Models CP6-CP32

On these models, there are LEDs that indicate whether the flow reading is in GPM or LPM. One of the two LEDs is lit all the time. Use the SET pushbutton to toggle between the two. If flow is available, the GPM and LPM flow rates will be displayed (again the LPM flow rate is greater than the GPM).

Upon supplying the initial DC power, the unit goes into a set-up mode. First, it will fill the LED display, showing that all segments of the display functions (8.8.8. is displayed), along with the GPM/LPM LEDs. Then it will display the firmware revision by stating the revision (4.5P for example). Then finally, it will go into the run mode and give the flow rate (or if no flow, 00.0).

When a flow alarm occurs, the second LED (either GPM or LPM) will blink as a visual indicator. Please note the solid LED indicates engineering units of the display and blinking indicates a flow alarm.

Configuring the solid state relay as alarm output:

1. Make sure the meter is in “flow” display mode. The **MENU** pushbutton is used to toggle between the “flow” and “temperature” displays. When in “flow” mode, either the **GPM** or the **LPM** LED lights up (both °F and °C LEDs will be off).
2. Press and hold **MENU**.
3. “FLo” is displayed, followed by either “PUL” (for pulse output) or “ALA” (for alarm output).
4. Release the **MENU** pushbutton.
5. If “ALA” is displayed, press the **SET** pushbutton.
6. If “PUL” is displayed, use the **MENU** pushbutton to change it to “ALA”, then press the **SET** button.
7. The 3-digit value that is displayed is the alarm setpoint (as stored in the memory).
8. Use the **MENU** button to change the alarm setpoint, if needed.

Note 1: When **MENU** is pressed once, the display increments to the next value. If the **MENU** button is held down, the display will initially increment slowly, then increment more quickly until the maximum allowed setpoint is reached. It will then roll over to 0 and start from the minimum setpoint again. Please refer to Table 1 for the range of acceptable flow setpoints for each flowmeter size.

Note 2: When the setpoint is 0, the flow alarm is disabled.

9. Press the **SET** pushbutton to store the new setpoint in the memory.
10. The LED then displays either “nc” (normally-closed) or “no” (normally-open). This is the state of the relay when there is no flow alarm.
11. Use the **MENU** pushbutton to toggle between “nc” and “no”.
Use the **SET** pushbutton to store the new relay configuration in memory.

12.

Meter Size	Setpoint Min.		Setpoint Max.		Hysteresis	
	GPM	LPM	GPM	LPM	GPM	LPM
¼"	0.40	1.5	3.00	12.0	0.10	0.4
¾"	3.0	11	22.5	85	1.2	5
1"	7.5	30	45.0	170	2.5	9
1 ½"	15	56	90	341	5	18
2"	30	113	180	682	10	37
3"	40	151	280	1059	15	57
4"	80	302	560	2119	30	114

Table 2. Flow Alarm Range

Note: Flow alarm is activated when flow \leq setpoint. After flow alarm is activated, it can only be cleared when flow $>$ setpoint + hysteresis . The term “activated” means that the relay contact is closed when “no” is selected (Steps 10 and 11 above), or opened when “nc” is selected.

Configuring the solid state relay as pulse output:

In order to configure the flowmeter for scaled-pulse output, proceed as follows:

1. Make sure the meter is in “flow” display mode. The **MENU** pushbutton is used to toggle between the “flow” and “temperature” displays. When in “flow” mode, either the **GPM** or the **LPM** LED lights up (both °F and °C LEDs will be off).
2. Press and hold **MENU**.
3. “FLo” is displayed, followed by either “PUL” (for pulse output) or “ALA” (for alarm output).
4. Release the **MENU** pushbutton.
5. If “PUL” is displayed, press the **SET** pushbutton.
6. If “ALA” is displayed, use the **MENU** pushbutton to change it to “PUL”, then press the **SET** button.

Pulse Output:

There is an output pulse proportional to flow “rate” as well. The pulse output always indicates flow in GPM. It is driven by an internal solid-state relay with a 10K pull-up resistor to supply voltage (pulse width = 3 msec). It should be noted that the pulse output represents instantaneous flow rate, not an averaged value. Therefore, flow jitter may be present when an external rate indicator is used, unless the indicator is capable of filtering or signal averaging.

The totalizer resolution and the corresponding flow rate pulse output depend on the full-scale setting of the flowmeter, as follows:

Port Size	Full-scale flow (GPM)	Pulse Output (Per Gallon)	Totalizer Resolution	Max. Count
¾”	25.0	100	0.1	99999.9
1”	50.0	100	0.1	99999.9
1 ½”	100	100	1	999999
2”	200	25	1	999999
3”	300	25	1	999999
4”	600	25	1	999999

Configuring response time in filter mode:

The response time for all models (except E4 or D2) can be configured by the user in the range of 0.9 to 7.5 seconds (63% step response). This is achieved by adjusting the “filtering” array size. Slower response typically provides a more steady output signal, as the instantaneous flow variation (dependent on pump, piping, etc.) is averaged out.

It should be noted that the response time refers to the D/A (analog 4-20 mA) output of the flowmeter. The LED display has a slower update rate.

In order to set the response time, proceed as follows:

1. Make sure the meter is in “flow” display mode.
2. Press and hold the **MENU** button until “Flo” is displayed.
3. Release the **MENU** button.
4. Depending on the output mode, either “PUL” or “ALA” will be displayed.
5. After approximately 5 seconds “FLt” will be displayed.
6. When “FLt” is displayed, press the **SET** button.
7. The current filter setting will be displayed (2, 4, 8, 16, or 32 samples averaged to produce the output). The letter “F” will be a prefix to the filter value.

Response time for each setting is as shown in the table:

FLt value	Response Time (sec)
2	0.9
4	1.4
8	2.3
16	4.0
32	7.5

8. To change the filter array size, press and release **MENU**. Alternately, you can press and hold the **MENU** button and see the values scroll.
9. When the desired filter size is selected, press the **SET** button.
10. After the filter size is changed, the meter will reboot itself for the changes to take effect.

Step Response Graphs for Various Filter Settings

The following graphs show some examples of the step-response behavior of the meter for various filter settings. The output shown is the 4-20mA flow signal going from zero to full-scale flow, through a 250-ohm load resistor (no filtering on the analog signal as shown). It is recommended that the user utilizes a filter component (e.g., a 0.1 uF capacitor across the load resistor) after installation.

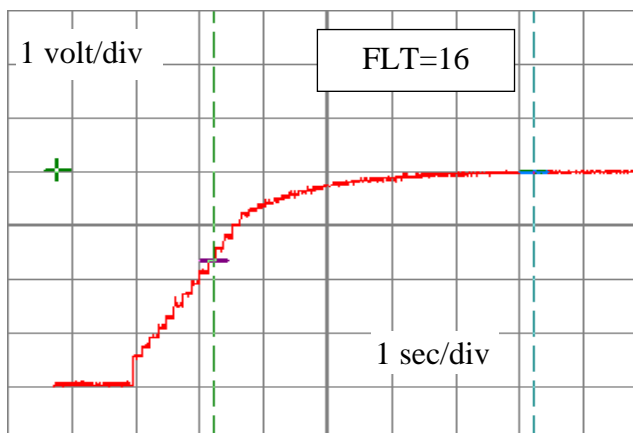
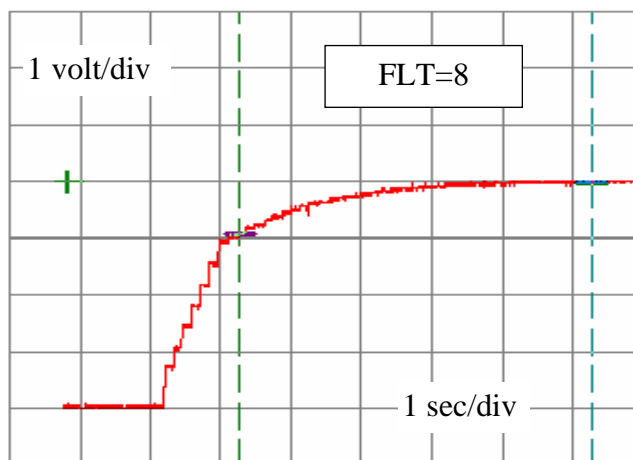
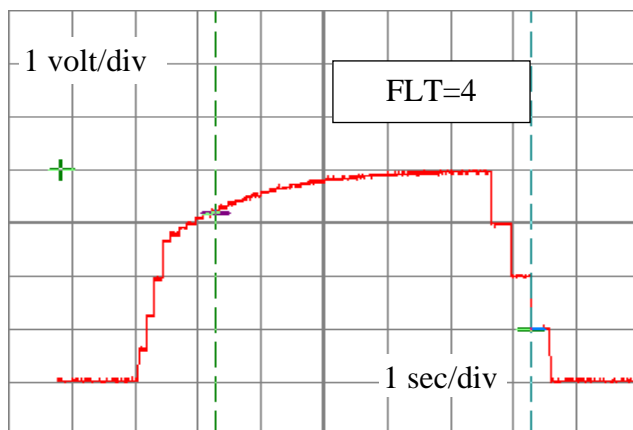

Configuring the CP models with the E2:

In order to configure the flowmeter for the alarm output, proceed as follows:

1. Press and hold the **MENU** pushbutton.
2. “Flo” is displayed, followed by “ALA” (for alarm output).
3. Release the **MENU** pushbutton.
4. When “ALA” is displayed, press and release the **SET** pushbutton.
5. “LSP” is displayed for the low flow alarm setpoint. Pressing and releasing the **MENU** pushbutton will change the display to “HSP” for the high flow alarm setpoint.
6. After selecting the desired flow alarm, press and release the **SET** pushbutton.
7. The value that is displayed is the alarm setpoint (as stored in memory).

Note 1: When the **MENU** is pressed once, the display increments to the next value. If the **MENU** button is held down, the display will initially increment slowly, then increment more quickly until the maximum allowed setpoint is reached. It will then roll over to 0 and start from the minimum setpoint again. Please refer to Table 1 for the range of acceptable flow setpoints for each flowmeter size.

Note 2: The hysteresis for the “LSP” is added to the setpoint and the low flow alarm will be de-activate as the flow increases from the low flow setpoint to (low flow + hysteresis). The hysteresis for the “HSP” is subtracted from the setpoint and the high flow alarm will de-activate as the flow decreases below the high flow setpoint to (high flow – hysteresis).

Note 3: When either or both of the setpoint(s) are zero, the flow alarm(s) are disabled.

8. Press the **SET** pushbutton to store the new setpoint to memory.
9. The LED then displays either “nc” (normally closed) or “no” (normally open). This is the state of the relay when there is no flow alarm.
10. Use the **MENU** pushbutton to toggle between “nc” and “no”.
11. Use the **SET** pushbutton to store the new relay configuration in memory.

NOTE: The “LSP” and “HSP” relay contacts are independent of each other and can be set to “nc” or “no” for the flow alarms. When either or both of the alarms are on, the alarm LED will blink.

MODEL CODES

CPMedium

How To Order *Select the appropriate symbols to build a model code:*

STANDARD CONSTRUCTION FOR BASIC PRODUCTS

FLOW ONLY	Model Code	Pipe Size Inches	Thread or Connection Type	Max Flow Rate GPM (LPM)	10:1 Turndown Min Flow Rate GPM (LPM)	20:1 Turndown (optional) Min Flow Rate GPM (LPM)
	CP6	3/4	NPT	25 (95)	2.5 (9.5)	1.25 (4.75)
	CP8	1	NPT	50 (190)	5.0 (19.0)	2.5 (9.5)
	CP12	1 1/2	NPT	100 (380)	10.0 (38.0)	5 (19)
	CP16	2	NPT	200 (750)	20.0 (75.0)	10 (37.5)

Standard models have fixed flow rates for each pipe size, brass construction, Viton® seals, 4-20mA output with programmable set point or pulse out selectable.

FLOW AND TEMPERATURE

	Model Code	Pipe Size Inches	Thread or Connection Type	Max Flow Rate GPM (LPM)	10:1 Turndown Min Flow Rate GPM (LPM)	20:1 Turndown (optional) Min Flow Rate GPM (LPM)
	CT6	3/4	NPT	25 (95)	2.5 (9.5)	1.25 (4.75)
	CT8	1	NPT	50 (190)	5.0 (19.0)	2.5 (9.5)
	CT12	1 1/2	NPT	100 (380)	10.0 (38.0)	5 (19)
	CT16	2	NPT	200 (750)	20.0 (75.0)	10 (37.5)

Example: CP12 is an 1 1/2 inch flowmeter with above characteristics.

For Special Options - Added symbols required.

Example: CP12-T2 is a standard model with BSPT threads.

SPECIAL OPTIONS AVAILABLE

Thread type or connection type	Flow rate GPM (LPM)	Body material	Switch and electronic options	Connector or conduit box	Enhanced Performance
BSPT = T2	4 (15) = F1 6 (23) = F9	316 SS = M2		Pig tails = C2	20:1 Turndown = W1
BSPP = T3	12 (45) = F2			Conduit box, terminal strip = C3	
	25 (95) = F3 50 (190) = F4		Temperature max to 225° for one hour wherein the 4-20 mA signal functions but the set points do not = E15		
	100 (380) = F5				

SPECIAL OPTION AVAILABILITY BY PIPE SIZE AND UNIT TYPE

Model Code	Pipe size in inches					
CP6	3/4	= T2, T3		= M2	= E15	= C2, C3 = W1
CP6-F1D2	3/4	= T2, T3	= F1*	= M2	= E15	= C2, C3
CP6-F9D2	3/4	= T2, T3	= F9*	= M2	= E15	= C2, C3 = W1
CP6-F2D2	3/4	= T2, T3	= F2*	= M2	= E15	= C2, C3 = W1
CP8	1	= T2, T3	= F3	= M2	= E15	= C2, C3 = W1
CP12	1 1/2	= T2, T3	= F4	= M2	= E15	= C2, C3 = W1
CP16	2	= T2, T3	= F5	= M2	= E15	= C2, C3 = W1
CT6	3/4	= T2, T3		= M2		= C2, C3 = W1
CT6-F1	3/4	= T2, T3	= F1*	= M2		= C2, C3
CT6-F9	3/4	= T2, T3	= F9*	= M2		= C2, C3 = W1
CT6-F2	3/4	= T2, T3	= F2*	= M2		= C2, C3 = W1
CT8	1	= T2, T3	= F3	= M2		= C2, C3 = W1
CT12	1 1/2	= T2, T3	= F4	= M2		= C2, C3 = W1
CT16	2	= T2, T3	= F5	= M2		= C2, C3 = W1

*These symbols are already incorporated in the basic model code at the left but are repeated here for clarity.

CPLarge

How To Order *Select the appropriate symbols to build a model code:*

STANDARD CONSTRUCTION FOR BASIC PRODUCTS

Model Code	Pipe Size Inches	Thread or Connection Type	Max Flow Rate GPM (LPM)	10:1 Turndown Min Flow Rate GPM (LPM)
CP24	3	ANSI RF	300 (1136)	30.0 (114)
CP32	4	ANSI RF	600 (2271)	60.0 (227)

FLOW AND TEMPERATURE

CT24	3	ANSI RF	300 (1136)	30.0 (114)
CT32	4	ANSI RF	600 (2271)	60.0 (227)

Standard models have fixed flow rates for each pipe size, brass construction, Viton® seals, 4-20mA output with programmable set point or pulse out selectable.

Example: CP24 is an 3 inch flowmeter with above characteristics.

For Special Options - Added symbols required.

Example: CP24-C2 is a standard model with pigtails for wiring instead of a pin connector.

SPECIAL OPTIONS AVAILABLE

Switch and electronic options	Connector or conduit box
	Pig tails = C2
	Conduit box, terminal strip = C3
Temperature max to 225° for one hour wherein the 4-20 mA signal functions but the set points do not = E15	

PRESSURE DROP CHARTS

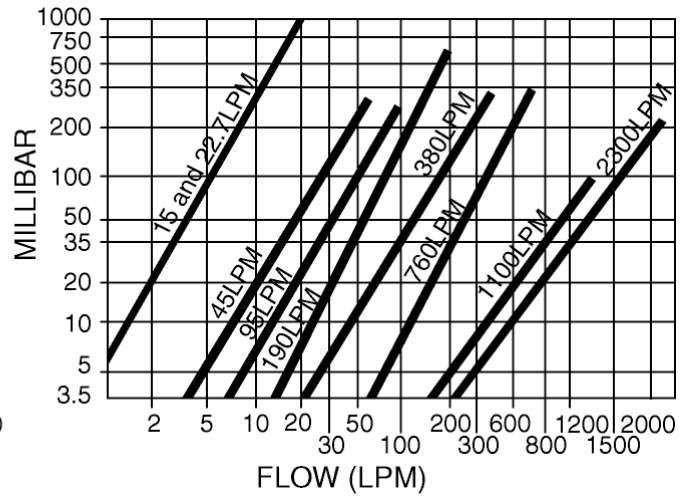
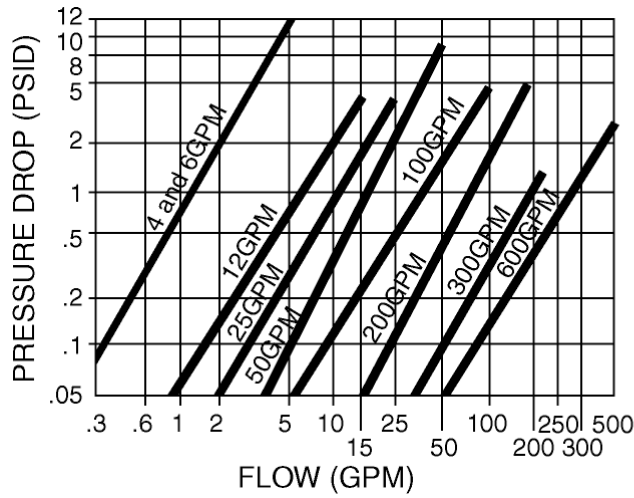

CABLING

ACCESSORY CABLES AVAILABLE FOR PIN CONNECTOR METERS			
Series	Description	Length in Meters	Part Number
CP	4 pin female	1	2519-1M
		3	2519-3M
		10	2519-10M
CP	5 pin female	1	6241-1M
		3	6241-3M
		10	6241-10M
CT	8 pin female	2	6242-2M
		5	6242-5M
		10	6242-10M

UNIVERSAL FLOW MONITORS, INC.

DIMENSIONS

INSTALLATION DRAWING – BASIC METERS

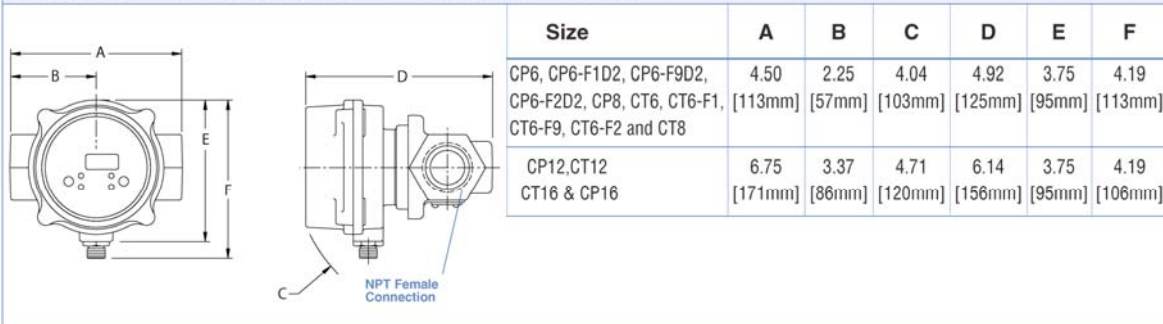

INSTALLATION DRAWING – METERS WITH OPTIONAL JUNCTION BOX

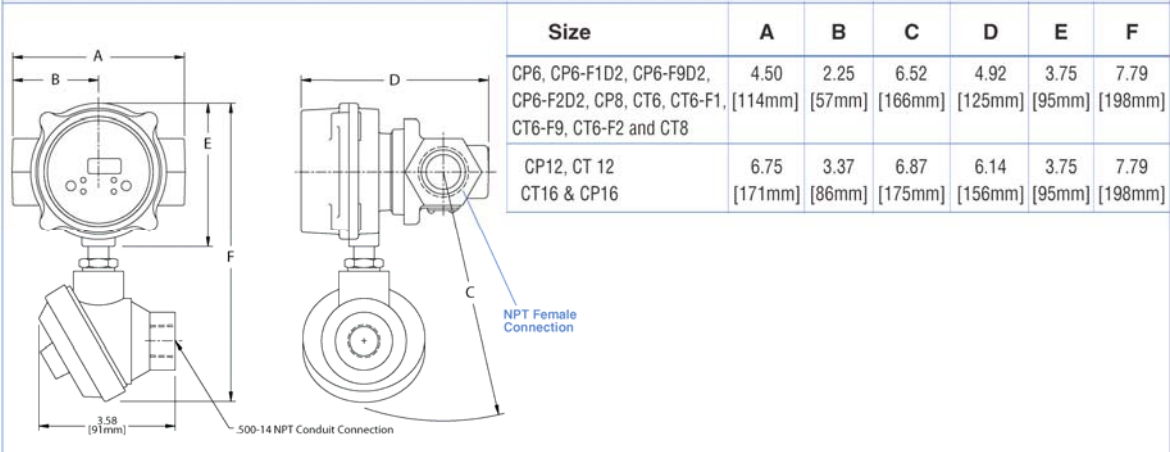

INSTALLATION DRAWING – 3" AND 4" PORT SIZE

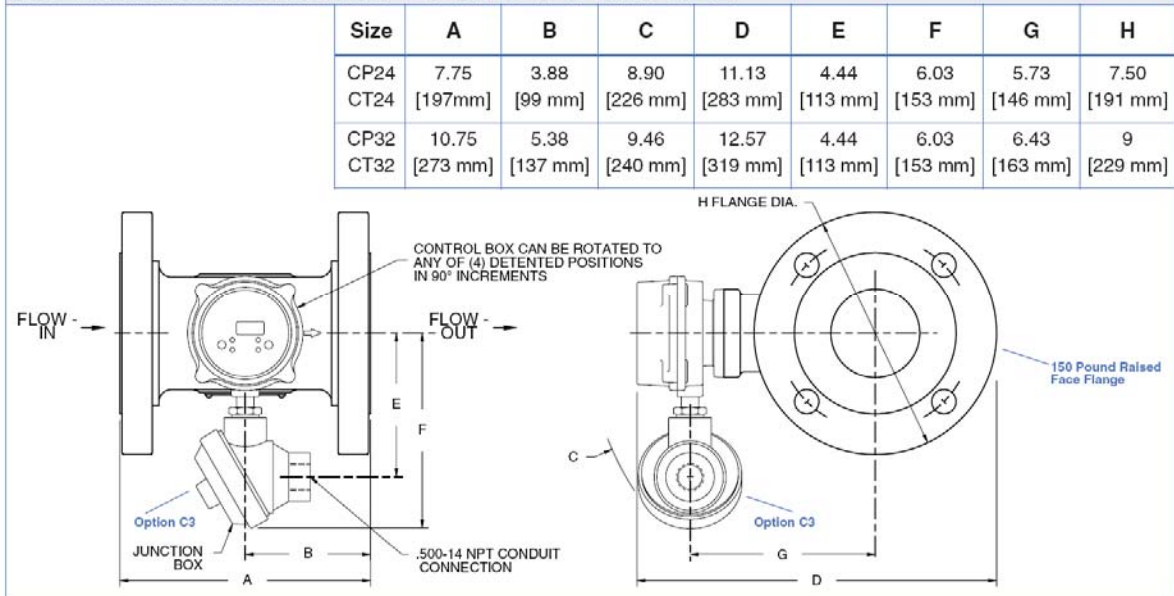

RMA NOTICE RETURN MERCHANDISE AUTHORIZATION

Please read the following UFM policy information carefully. By following the guidelines outlined below you will assist in providing a timely evaluation and response regarding the status of your flow meter. UFM evaluates all AUTHORIZED RETURNED MATERIALS in a timely manner and will promptly provide notification regarding the status of the related materials and/or a written quotation indicating the total charges and description of the necessary repairs.

- 1 All returns must have a RMA form completed by the customer.
- 2 Any meter returned that was previously in service must have the OSHA requirements completed and a MSDS included where applicable.
- 3 An RMA number will only be issued when UFM has received a copy of the completed RMA form and any applicable MSDS.
- 4 A "Return Goods" shipping label (located in the back of the Instruction Manual) must be used for returning materials to UFM.
- 5 Returned goods must be shipped prepaid or they will be rejected.

REPAIRABLE MATERIAL

Written or verbal authorization to proceed with the repair under an assigned Purchase Order, must be received within 30 days of repair quotation. If the unit(s) are repaired, the \$90.00 evaluation charge will be applied to the quoted repair costs. If no repairs are authorized within this 30 day period, the customer will be billed \$90.00 plus shipping charges and the materials will be returned to the customer.

NON-REPAIRABLE MATERIAL

If materials are found not repairable, a written notice that the material is not repairable will be provided to the customer by UFM. If no disposition to scrap or return the material is received from the customer within 30 days, unrepairable material will be scrapped and the customer will be billed the \$90.00 evaluation charge. If a UFM replacement unit is purchased within 30 days of non-repairable condition notice, the \$90.00 evaluation fee will be waived. The return of non-repairable materials may be ordered by customer Purchase Order providing for shipping and handling charges.

RETURN FOR RESTOCK All goods returned for restock adjustment **must** be:

A. New and unused.

B. **Returned to the factory within ONE YEAR of date of original shipment.**

C. Returned through the distributor where the goods were originally purchased. This material will also be subject to an evaluation charge of \$90.00.

The customer will be advised of the restocking adjustment for all restockable goods. Upon acceptance of the restocking adjustment, by the customer, the \$90.00 evaluation fee will be waived and a credit issued by UFM. The customer will be advised of any **non-restockable** goods and will be charged the \$90.00 evaluation fee plus any shipping charges if returned to the customer.

If no disposition is received by UFM within 30 days, the goods will be scrapped and the \$90.00 evaluation fee will be billed.

WARRANTY RETURNS

Warranty returns must be shipped prepaid to UFM. UFM will review the goods and advise the customer of the evaluation and validity of the warranty claim. Valid warranty claims will be repaired or replaced at no charge. No evaluation fee will be charged for repairs made under warranty. Return shipping costs will be prepaid by UFM. Should UFM determine the returned material is not defective under the provisions of UFM's standard warranty, the customer will be advised of needed repairs and associated costs. All materials returned for warranty repair that are determined to not have a valid warranty claim will be subject to the "**Repairable Material**" policy outlined above.

UNIVERSAL FLOW MONITORS, INC.

RMA FORM

<p style="text-align: center;">UNIVERSAL U M FLOW MONITORS ROCON LLC</p>	<p>RETURN MATERIAL AUTHORIZATION E-MAIL: ufm@flowmeters.com 1755 E. Nine Mile Rd., Hazel Park MI 48030 PH: (248) 542-9635 Fax: (248) 398-4274</p>
--	--

IMPORTANT: This form must be filled out completely and faxed to the Repair Department prior to issuing a RMA # (UFM) / NRA # (ROCON)

Customer: _____	Product Information	Qty: _____
_____	Model Code: _____	_____
_____	S/N: _____	_____
_____	Sales Order: _____	_____
Contact Name: _____	_____	
Phone # _____	_____	
FAX # _____	Are before (as found) and after readings required?	
E-mail: _____	_____ Yes _____ No	
Reason for return: (Please be detailed as possible. Lack of Information may increase labor charges.)		
<p>Mechanical</p> <input type="checkbox"/> Leaks <input type="checkbox"/> Sticks <input type="checkbox"/> Calibration Off <input type="checkbox"/> Switch does not work <input type="checkbox"/> Other (describe below)	<p>Electronics</p> <input type="checkbox"/> No signal <input type="checkbox"/> Inaccurate signal <input type="checkbox"/> No Display <input type="checkbox"/> Other (describe below)	
Details: _____		

<p>Note: There will be a minimum evaluation charge of \$90.00 for all units returned (excluding units covered under warranty). Units WILL NOT be accepted without a valid Return Material Authorization Number (RMA#). A Material Safety Data Sheet on the process fluid must be received, when applicable, prior to the RMA# being issued.</p>		
* OSHA Requirements: (to be filled out by customer) NO EXCEPTIONS!!		
Process Fluid: _____		
Meter must be flushed to remove all process fluids.		
I hereby certify that the material being returned has been properly flushed and cleaned of all hazardous materials and does not require any special handling.		
Print or Type Name _____	Signature: _____	
Title _____	Date: _____	

<p>Distributor Information <i>INTERNAL USE ONLY</i></p> Company Name _____ Contact Name _____ PO # _____ Phone # _____ FAX # _____	<p># _____</p> <p>Authorized by _____</p> <p>Date _____</p>
--	---

WARRANTY INFORMATION

1) ACCEPTANCE AND INTEGRATION CLAUSE: This Sales Order Acknowledgment and the sales order information that Universal Flow Monitors, Inc. ("Universal") attaches to or associates with it (herein "Acknowledgment"), constitutes an acceptance by Universal of an offer by the buyer upon the conditions and terms and at the prices stated in this Acknowledgment. The Acknowledgment contains the entire understanding of Universal and the buyer regarding the subject matter of said Acknowledgment. This Acknowledgment may only be modified by a written agreement signed by the party against whom enforcement is sought.

2) WAIVER: Waiver by Universal of any default(s) by the buyer shall not constitute waiver by Universal of any of the conditions of the agreement between Universal and the buyer as set forth hereunder with respect to any further or subsequent default by the buyer.

3) FORCE MAJEURE: Universal shall not be responsible for failure or delays in deliveries due to fire, strikes, breakdowns, acts of God, failure of carriers, inability to secure required materials, or other causes beyond Universal's control. Buyer waives any claims for damage arising by virtue of delay in delivery of material by Universal.

4) LIMITED WARRANTY:

(a) Warranty. For a period of one year from the date of manufacture, Universal warrants that each product covered by this Acknowledgment will be free from defects in material and workmanship. In order to qualify for any remedy provided in this Acknowledgment, buyer must give notice to Universal within the one-year period, return the product to Universal freight paid and intact with Material Safety Data Sheets covering all substances passing through the product or that form a residue on the product.

(b) Exclusive Remedy. The buyer's EXCLUSIVE REMEDY for failure of any product to conform to any warranty or otherwise for any defect is, at Universal's sole option: (i) repair; (ii) replacement; or (iii) refund of the entire purchase price for the specific product. Without limiting the foregoing, in no case will Universal be liable for de-installation of any defective product or installation of any repaired or replaced product. THIS REMEDY IS THE EXCLUSIVE REMEDY AVAILABLE TO THE BUYER OR ANY OTHER PERSON. UNIVERSAL SHALL NOT BE LIABLE FOR ANY DIRECT, INDIRECT, INCIDENTAL, CONSEQUENTIAL, SPECIAL, PUNITIVE, OR OTHER DAMAGES IN CONNECTION WITH ANY CAUSE OF ACTION, WHETHER IN CONTRACT, TORT, OR OTHERWISE.

(c) Disclaimer of Other Warranties. The express warranty in this Acknowledgment is in lieu of any other warranty, express or implied. Without limiting the foregoing, UNIVERSAL DISCLAIMS THE IMPLIED WARRANTY OF MERCHANTABILITY AND ANY IMPLIED WARRANTY OF FITNESS FOR A PARTICULAR PURPOSE.

(d) Special Note About Fitness for a Particular Purpose. This website and other materials of Universal may place products into, or display products in, categories according to function, size, construction, materials, or other property. This is for organizational purposes only and NO PLACEMENT OF ANY PRODUCT IN ANY CATEGORY OR ANY PRESENTATION OF A PRODUCT IN RELATION TO OTHER PRODUCTS WILL CONSTITUTE A WARRANTY OF FITNESS FOR A PARTICULAR PURPOSE.

5) PROHIBITED USES: As a condition of the sale of goods or services, buyer will not use, sell, distribute, or otherwise transfer for use, or permit to be used, sold, distributed, or otherwise transferred any product purchased from Universal for any of the following uses:

(a) Nuclear Energy Applications. Any application involving, directly or indirectly: (i) exposure of any product to any hazardous properties of nuclear material; (ii) dependence on the proper functioning of the product for the operation of a nuclear facility by any person or organization; (iii) use in or for any equipment or device used for the processing, fabricating or alloying of special nuclear material if, at any time, the total amount of such material on the premises where such equipment or device is located consists of or contains more than 25 grams of (A) Plutonium (any isotope) or Uranium 233 or any combination thereof; (B) more than 250 grams of Uranium 235; (iv) use in, or for the control of any aspect of, any structure, basin, excavation, premises or place prepared or used for the storage or disposal of waste. The foregoing include, without limitation, any application involving nuclear material contained in spent fuel or waste that is possessed, handled, used, processed, stored, transported or disposed of, any application related to the furnishing of services, materials, parts or equipment in connection with the planning, construction, maintenance, operation or use of any nuclear facility.

(b) Aircraft Applications. Any application involving direct or indirect installation in or on, or use in connection with, any aircraft or aircraft product.

(c) Definitions. As used in this section, the following definitions apply, whether the terms use initial capitals or not.

"Aircraft" includes powered and non-powered winged aircraft, missiles, spacecraft, and other aeronautical craft or mechanisms.

"Aircraft product" includes:

(1) Any ground support or control equipment used with any aircraft;

(2) Any article designed for installation in or on aircraft;

(3) Any ground handling tools or equipment used with aircraft;

(4) Any aircraft training aids, instructions, manuals, or blueprints; and

(5) Any engineering, labor or other services involving aircraft.

"Hazardous properties" include radioactive, toxic or explosive properties;

"Nuclear facility" means

(a) Any nuclear reactor; or

(b) Any equipment or device designed or used for:

(1) Separating the isotopes of uranium or plutonium;

(2) Processing or utilizing spent fuel; or

(3) Handling, processing or packaging waste.

"Nuclear material" means source material, special material or by-product material;

"Nuclear reactor" means any apparatus designed or used to sustain nuclear fission in a self-supporting chain reaction or to contain a critical mass of fissionable material.

"Property damage" includes all forms of radioactive contamination of property.

"Source material," "special nuclear material," and "by-product material" have the meanings given them in the Atomic Energy Act of 1954 and any regulation promulgated thereunder, as the same may be amended from time to time.

"Spent Fuel" means any fuel element or fuel component, solid or liquid that has been used or exposed to radiation in a nuclear reactor.

"Waste" means any waste material

(1) containing by-product material and

(2) resulting from the operation by any person or organization of any nuclear facility.